

OPERATING INSTRUCTIONS



TYPES **1214 -A, -D, -E,**  

---

**and -M**  
**UNIT OSCILLATORS**



G E N E R A L R A D I O C O M P A N Y  
WEST CONCORD, MASSACHUSETTS, USA

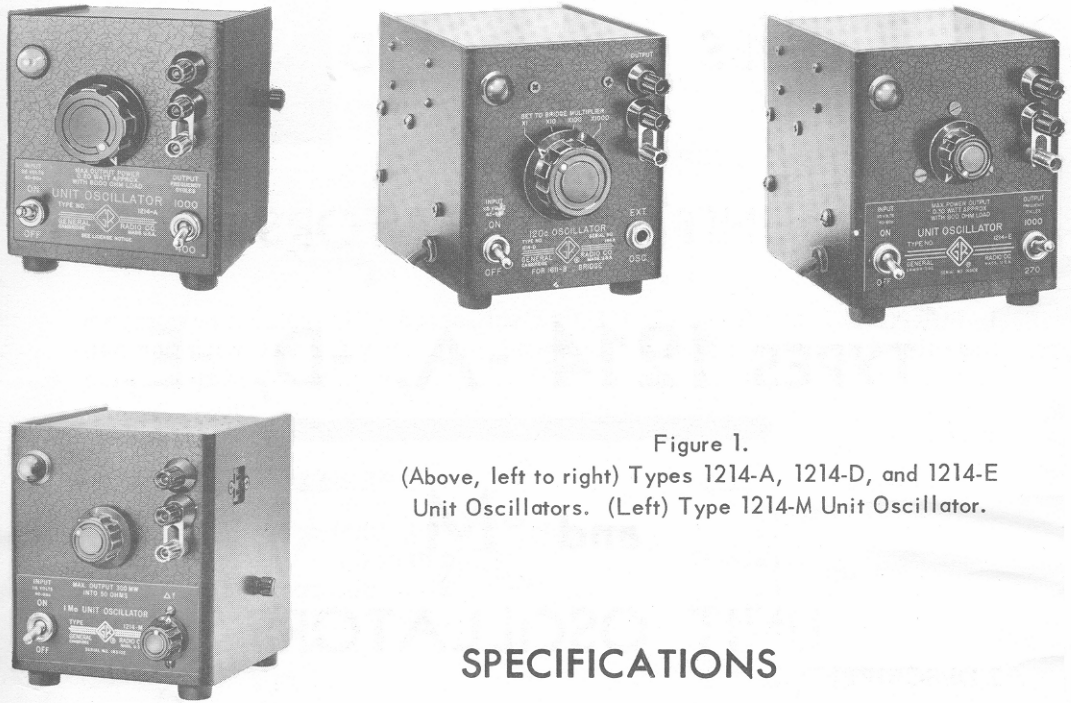

Figure 1.  
 (Above, left to right) Types 1214-A, 1214-D, and 1214-E  
 Unit Oscillators. (Left) Type 1214-M Unit Oscillator.

## SPECIFICATIONS

	1214-A	1214-D	1214-E	1214-M
FREQUENCY	400, 1000 cps	120 cps	270, 1000 cps	1 Mc
ACCURACY	±2%	See Note A	±2%	±1%
MAX OUTPUT	200 mw into 8000Ω	400 mw into 1,10,100, & 1000Ω (1611-B Bridge)	300 mw into 800Ω	300 mw into 50Ω
OPEN-CIRCUIT OUTPUT VOLTAGE	0-60 v	45, 13, 4.5 or 1.3	0-28 v	0-7 v
DISTORTION	3% into 8000Ω	3% into matched load	3% into 800Ω	3.5% into 50Ω
POWER INPUT	115 v, 40-60 cps	115 v, 40-60 cps	115 v, 40-60 cps	115 v, 40-60 cps
POWER CONSUMPTION	16 w	16 w	16 w	12 w
DIMENSIONS				
Height	5-3/4 in	5-3/4 in	5-3/4 in	5-3/4 in
Width	5 in	5 in	5 in	5 in
Depth	6-1/4 in	6-1/4 in	6-1/4 in	6-1/4 in
WEIGHT	4-1/2 lb	4-1/2 lb	4-1/2 lb	2-3/4 lb

Note A: ±5% when used with Type 1611-B Bridge. Open-circuit frequency is 122 cps ±2%.

# TYPES 1214-A, -D, -E, AND -M UNIT OSCILLATORS

1 PURPOSE. The Type 1214 Unit Oscillators (Figure 1) are compact, low-distortion signal sources intended primarily for use with companion General Radio instruments, but useful also as general-purpose laboratory oscillators. These Unit Oscillators cover the following frequencies:

<u>Type</u>	<u>Frequency</u>
1214-A	400, 1000 cps
1214-D	120 cps
1214-E	270, 1000 cps
1214-M	1 Mc

## 2 DESCRIPTION.

2.1 CIRCUIT. The Type 1214 Unit Oscillator includes a built-in transformerless power supply, which operates from 115 volts, 40 to 60 cps. (Direct current may be used, but performance may not be within specifications.) The oscillator is a Hartley circuit, with the coil tapped for 1000-cps operation in the -A and -E models. The output circuit is coupled through an isolating pickup coil, and can be operated either grounded or ungrounded.

2.2 CONTROLS. Power is applied by means of an OFF-ON toggle switch on the panel. Other panel controls include a frequency selector toggle switch on the -A and -E models, plus the following:

<u>Name</u>	<u>Model</u>	<u>Type</u>	<u>Function</u>
Output Control	A, E, M	Continuous rotary control	Varies output power from zero to maximum.
SET TO BRIDGE MULTIPLIER	D	4-pos selector switch	Matches output to various bridge loads.
$\Delta f$	M	Continuous rotary control	Varies frequency $\pm 1\%$ from 1 Mc.

## GENERAL RADIO COMPANY

**2.3 CONNECTORS.** The output terminals of the Type 1214 Unit Oscillator are jack-top binding posts with 3/4-inch spacing. A link and separate ground binding post below the output pair permit grounded or ungrounded operation of the oscillator.

On the Type 1214-D, the EXT OSC panel jack permits use of the Type 1214-D's matching transformer with an external audio oscillator.

### 3 OPERATING PROCEDURE.

**3.1 TYPES 1214-A AND 1214-E.** Connect the device to be driven to the output binding posts. Connect the link between the lower two binding posts if grounded output is desired. Connect the Unit Oscillator to a 115-volt, 40-60-cps source, set the OUTPUT FREQUENCY switch to the desired frequency, and snap the power switch ON. The panel lamp should light to indicate application of power.

By means of the output control in the center of the panel, output power may be varied from zero to a maximum of 200 mw into an 8000-ohm load for the Type 1214-A, 300 mw into an 800-ohm load for the Type 1214-E.

**3.2 TYPE 1214-D.** When the Type 1214-D Unit Oscillator is used with the Type 1611-B Capacitance Test Bridge, the Unit Oscillator output terminals should be connected to the EXT GEN terminals of the bridge. Connect the third binding post of the oscillator to an external ground, preferably at the same point at which the bridge is grounded. For grounded output, connect the link between the lower two binding posts. Set the SET TO BRIDGE MULTIPLIER switch to the position corresponding to the setting of the bridge MULTIPLY CAPACITANCE BY switch. Connect the Unit Oscillator to a 115-volt, 40-60-cps source, and snap the power switch ON. The panel lamp should light to indicate application of power.

If an external audio oscillator is to be used with the Type 1214-D's matching transformer, connect the external oscillator to the EXT OSC jack, and connect the Type 1214-D output to the bridge EXT GEN connector. Set the bridge filter switch to EXT and connect an external filter to the bridge EXT FILTER jack.

Under normal operation, the output voltages delivered to the Type 1611-B bridge are as follows:

<u>Multiplier</u>	<u>Capacitance</u>	<u>Volts</u>	<u>Multiplier</u>	<u>Capacitance</u>	<u>Volts</u>
X 1	1	37	X 100	100	4.8
	10	31		1000	4.8
X 10	10	16	X 1000	1000	1.6
	100	15		10,000	1.6

## TYPES 1214-A, -D, -E, AND -M UNIT OSCILLATORS

3.3 TYPE 1214-M. Connect the device to be driven to the output of the Type 1214-M, using either the side multipoint connector (see Figure 12 for proper connections) or the panel jack-top binding posts. For grounded output, connect the link between the lower two binding posts. Connect the Unit Oscillator to a 115-volt, 40-60-cps source, and snap the power switch ON. The panel lamp should light to indicate application of power.

By means of the output control in the center of the panel, output power can be varied from zero to 300 milliwatts into a 50-ohm load. To compensate for frequency shift with changing load conditions, or to match the output frequency to the frequency of an external filter or other tuned device, the  $\Delta f$  control will vary the output frequency  $\pm 1\%$  from 1 Mc.

### 4 SERVICE AND MAINTENANCE.

4.1 GENERAL. The two-year warranty given with every General Radio instrument attests the quality of materials and workmanship in our products. When difficulties do occur, our service engineers will assist in any way possible.

In case of difficulties that cannot be eliminated by the use of these service instructions, please write or phone our Service Department, giving full information of the trouble and of steps taken to remedy it. Be sure to mention the serial and type numbers of the instrument.

Before returning an instrument to General Radio for service, please write to our Service Department or nearest district office (see back cover), requesting a Returned Material Tag. Use of this tag will insure proper handling and identification. For instruments not covered by the warranty, a purchase order should be forwarded to avoid unnecessary delay.

4.2 REMOVAL OF COVER. To remove the cover, loosen the thumb-screw on the right-hand side of the instrument and slide the cover off, away from the panel. With the cover off, tubes and fuses are accessible.

4.3 TEST VOLTAGES AND RESISTANCES. The following test voltages and resistances are given to aid in trouble-shooting. Due to the direct connection to the power line, the oscillator and power-supply circuits are not grounded to the chassis. Voltage measurements are therefore referred to pin 2 of the Type 117N7GT tube. D-C voltages were measured with a 20,000-ohm/volt meter. Resistance measurements were made with pin 8 connected to pin 2, and with power off.

GENERAL RADIO COMPANY

TABLE OF VOLTAGES

V1, PIN	VOLTS TO PIN 2			
	1214-A	1214-D	1214-E	1214-M
1	0	0	0	0
2	0	0	0	0
3	112	94	120	112
4	-10	-45	-13	-43
5	92	96	94	112
6	0	0	0	0
7	115 ac	115 ac	115 ac	115 ac
8	123	109	120	116

TABLE OF RESISTANCES

V1, PIN	RESISTANCE TO GROUND (in ohms)			
	1214-A	1214-D	1214-E	1214-M
1	$\infty$	$\infty$	$\infty$	$\infty$
2	0	0	0	0
3	330	350	320	300
4	1 M	1 M	1 M	300 k
5	4.7 k	295	8.5 k	300
6	0	0	0	0
7	180	180	180	180
8	0	0	0	0

NOTE: For conditions of measurement,  
refer to paragraph 4.3.



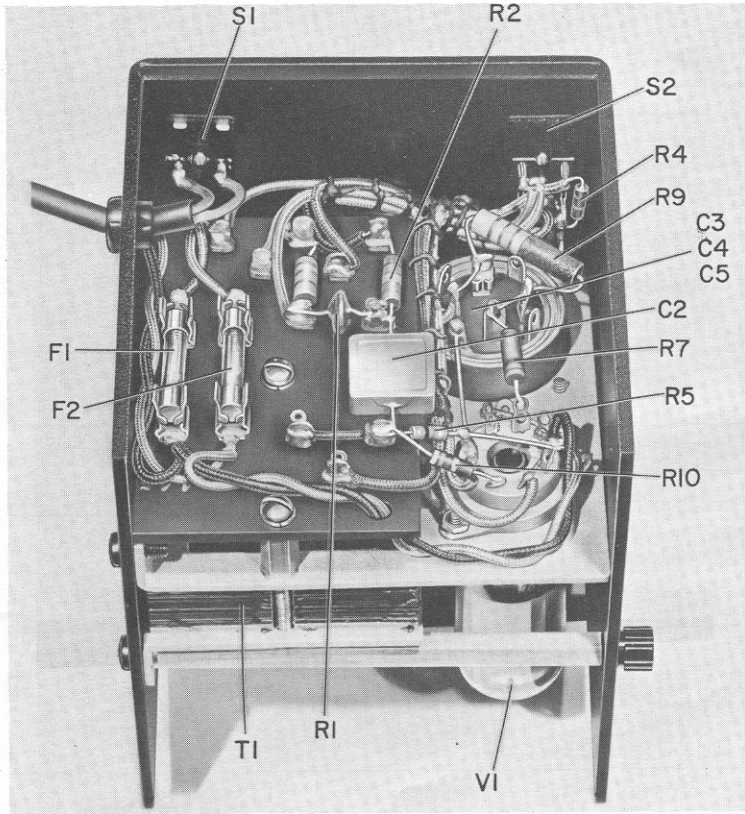

Figure 2. Interior View, Type 1214-A Unit Oscillator.



# TYPES 1214-A, -D, -E, AND -M UNIT OSCILLATORS

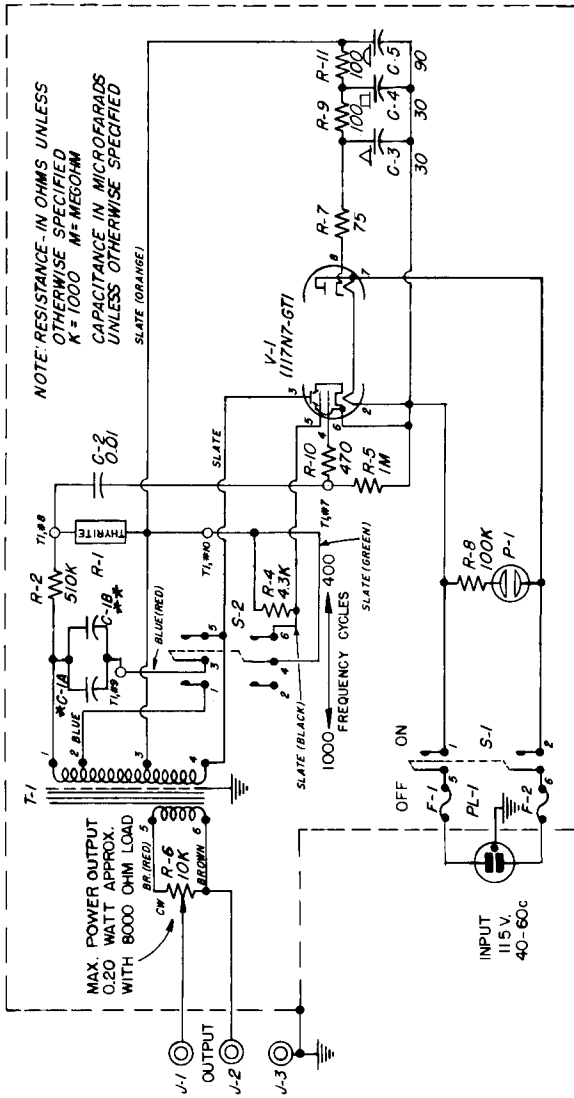

Figure 3. Schematic Diagram, Type 1214-A Unit Oscillator.

GENERAL RADIO COMPANY

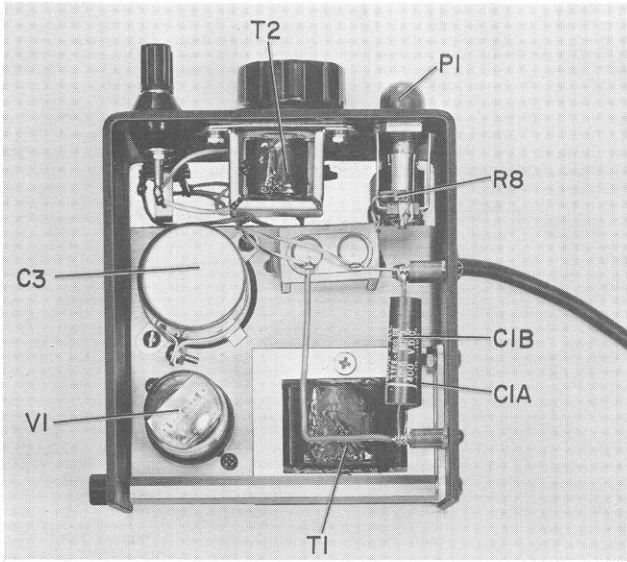

Figure 4. Top Interior View, Type 1214-D Unit Oscillator.

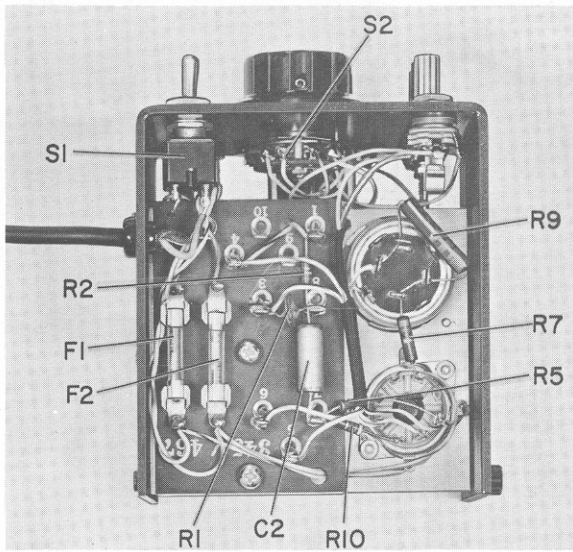

Figure 5. Bottom Interior View, Type 1214-D Unit Oscillator.

TYPES 1214-A, -D, -E, AND -M UNIT OSCILLATORS

NOTE:  
 RESISTORS 1/2 WATT UNLESS OTHERWISE SPECIFIED.  
 RESISTANCE VALUES IN OHMS UNLESS OTHERWISE SPECIFIED.  
 CAPACITANCE VALUES ONE μ OVER IN MICRO-MICROFARADS LESS THAN ONE IN MICROFARADS UNLESS OTHERWISE SPECIFIED.

SET TO BRIDGE MULTIPLIER  
 X1 X10 X100 X1000

S-2

ENGRAVING

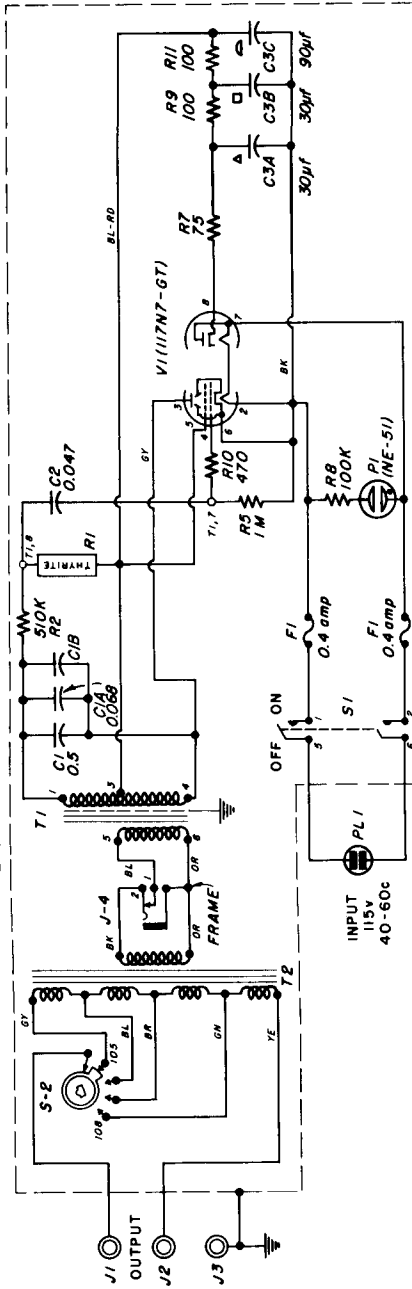

Figure 6. Schematic Diagram, Type 1214-D Unit Oscillator.

GENERAL RADIO COMPANY

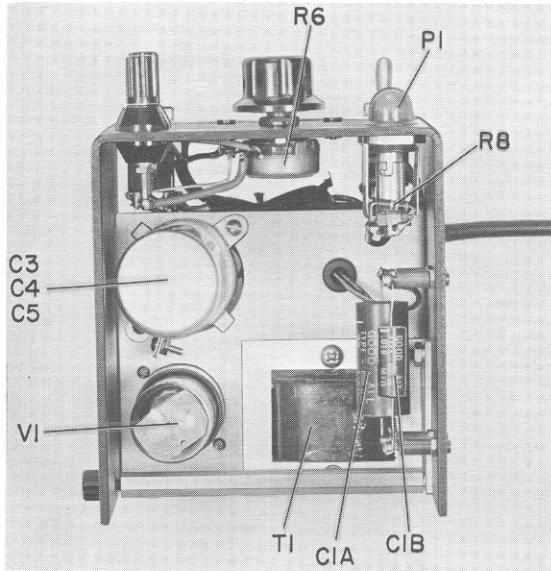

Figure 7. Top Interior View, Type 1214-E Unit Oscillator.

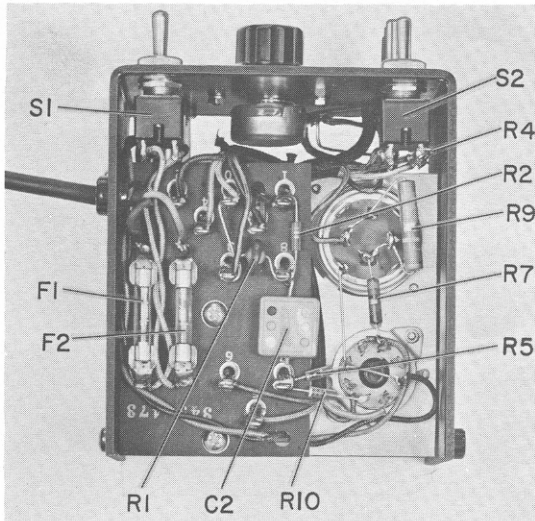

Figure 8. Bottom Interior View, Type 1214-E Unit Oscillator.

TYPES 1214-A, -D, -E, AND -M UNIT OSCILLATORS

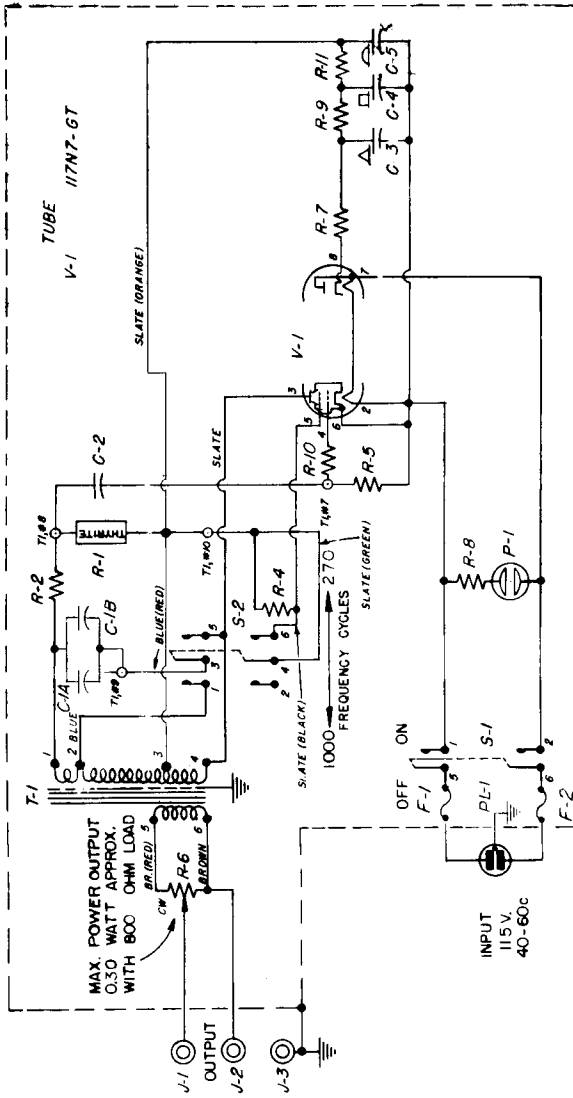

Figure 9. Schematic Diagram, Type 1214-E Unit Oscillator.

GENERAL RADIO COMPANY

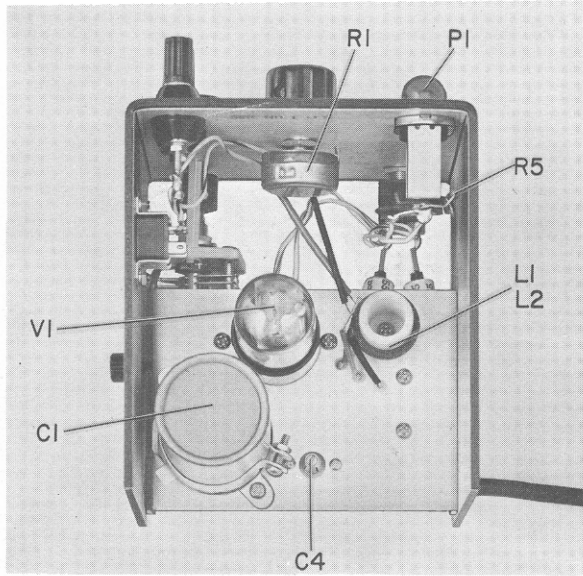

Figure 10. Top Interior View, Type 1214-M Unit Oscillator.

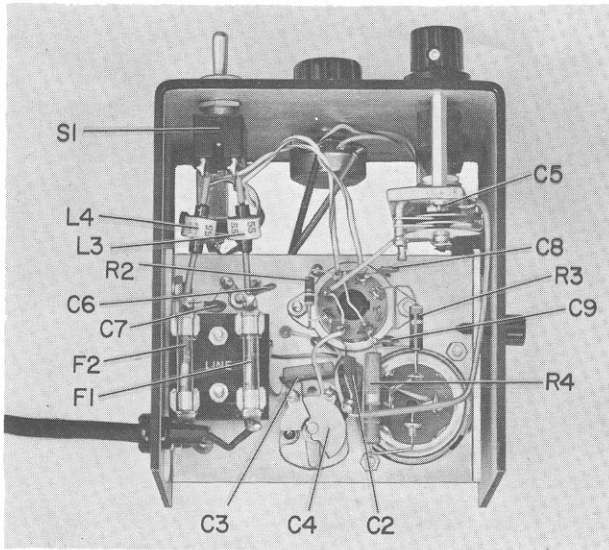

Figure 11. Bottom Interior View, Type 1214-M Unit Oscillator.

# TYPES 1214-A, -D, -E, AND -M UNIT OSCILLATORS

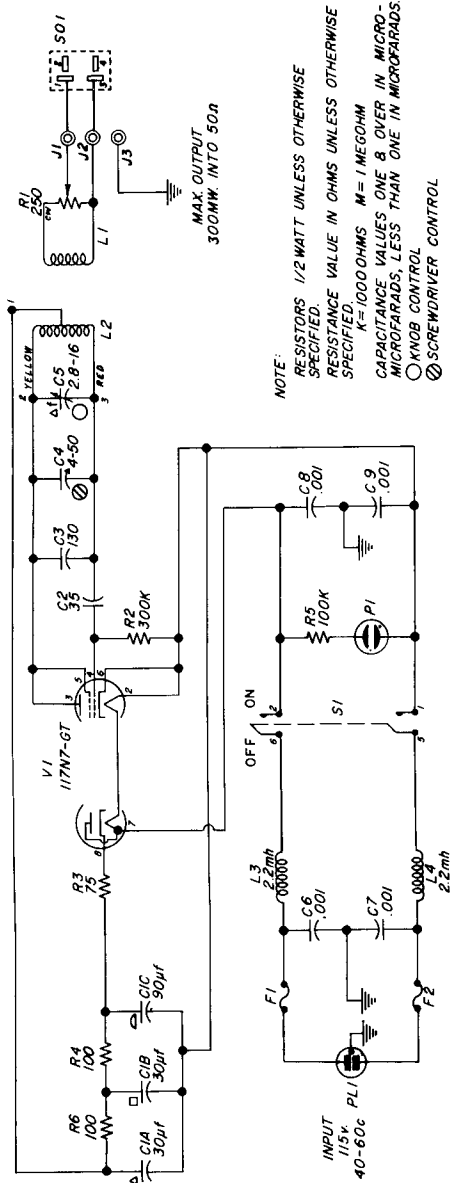

Figure 12. Schematic Diagram, Type 1214-M Unit Oscillator.

# GENERAL RADIO COMPANY

WEST CONCORD, MASSACHUSETTS

EMerson 9-4400

CLearwater 9-8900

## DISTRICT OFFICES

### NEW YORK

Broad Ave. at Linden, Ridgefield, N. J.  
Telephone N.Y. WOrth 4-2722  
N.J. WHitney 3-3140

### PHILADELPHIA

1150 York Rd., Abington, Penna.  
Telephone HAncock 4-7419

### WASHINGTON

8055 13th St., Silver Spring, Md.  
Telephone JUNiper 5-1088

### CHICAGO

6605 West North Ave., Oak Park, Ill.  
Telephone VillAge 8-9400

### LOS ANGELES

1000 N. Seward St., Los Angeles 38,  
Calif.  
Telephone HOLlywood 9-6201

### SAN FRANCISCO

1186 Los Altos Ave., Los Altos, Calif.  
Telephone WHitecliff 8-8233

### CANADA

99 Floral Pkwy., Toronto 15, Ont.  
Telephone CHerry 6-2171

## REPAIR SERVICES

### EAST COAST

General Radia Company  
Service Department  
22 Baker Ave., W. Concord, Mass.  
Telephone EMerson 9-4400

### NEW YORK

General Radia Company  
Service Department  
Broad Ave. at Linden, Ridgefield, N. J.  
Telephone N.Y. WOrth 4-2722  
N.J. WHitney 3-3140

### MIDWEST

General Radia Company  
Service Department  
6605 West North Ave., Oak Park, Ill.  
Telephone VIllage 8-9400

### WEST COAST

General Radia Company  
Service Department  
1000 N. Seward St., Los Angeles 38, Calif.  
Telephone HOLlywood 9-6201

### CANADA

Bayly Engineering, Ltd.  
First Street, Ajax, Ontario  
Telephone Toranta EMpire 2-3741